

GRS[®] MicroBlock[®] Ball Vice

INSTRUCTIONS • #003-683 & #003-684

The GRS MicroBlock[®] will provide many years of trouble-free service. It is extremely rugged in construction, yet is relatively simple and easy to maintain. Required lubrication is minimal.

The jaws are drilled to accept engraving block attachments. The MicroBlock[®] includes six socket head screws, which can be used to secure special items or fixtures. GRS offers the 520 Attachment Set (#003-520) that includes storage for the pins that come with the block.

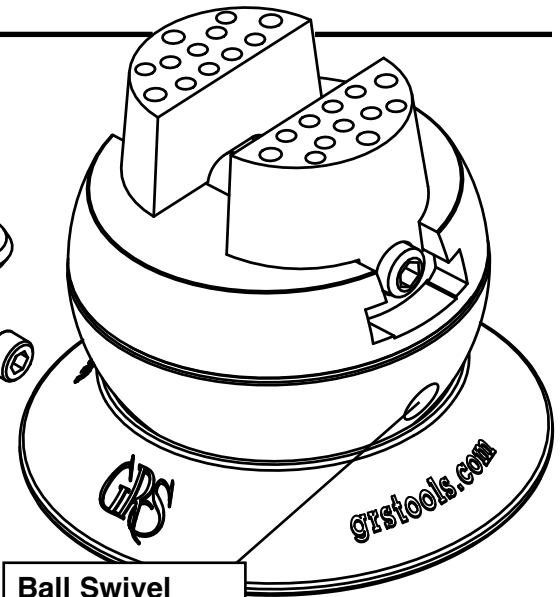
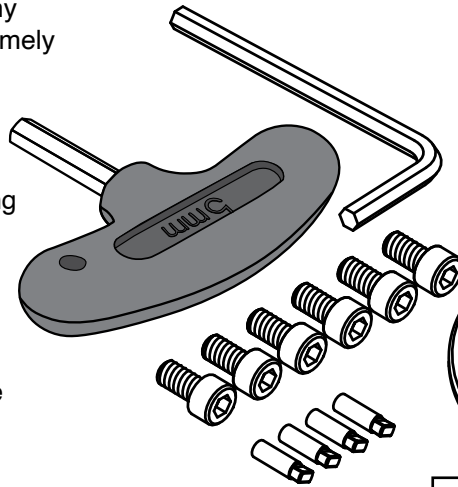

Maintenance

Based on usage, open jaws fully and clean dirt and metal pieces from the threads. After cleaning, apply a small amount of light oil to threads.

Jaw Thread Replacement

Overtightening the jaws will cause wear and damage to the threads. If jaws become loose, replace with kit #003-629. Remove the jaws by opening them as wide as possible until they come off the end of the jaw screw (**FIG. 1**). The jaw thread pin is located on the underside of each jaw. **NOTE:** Before removing pins, locate the one with the "L". This is the left hand thread pin and will need to be replaced with the same. Apply a small amount of synthetic grease (included in kit) to the O-ring and jaw screw before installing them. Lift the jaw screw out of the yoke and replace it. Note which side the left hand thread is on. Grease the threads and yoke well.

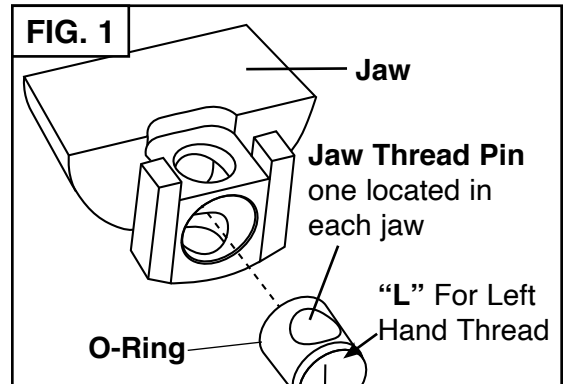

Start the jaw threads at the same time when replacing them (**FIG. 2**). Hold each jaw in position and turn the jaw screw to close them. Either a large rubber band or a second person is useful to hold the jaws against the thread while the jaw screw is turned. If the jaws don't meet at the same time in the center, remove them and try starting the threads at the same time again.

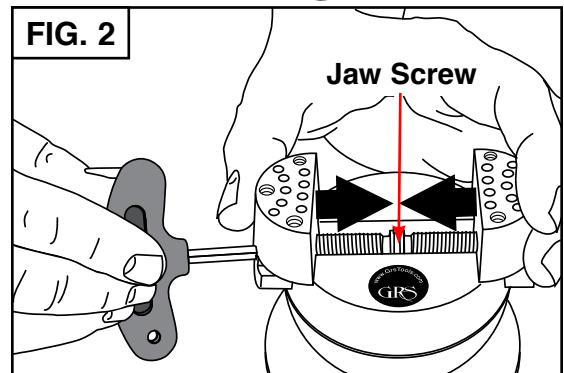

Rotational Lock Replacement

The LOCK or DRAG PIN is subject to wear by design and may need replacement after extended use. Simply remove the ball swivel tension screw with hex wrench. The Spring and Lock Pin should follow (**FIG. 3**). If not, turn the ball until they fall out. Replace the Lock Pin (order #003-307), Spring and Tension Screw.

Thread Pin Replacement Kit #003-629

Includes Jaw Screw, Left and Right Thread Pins, O-Rings, and Tube of Synthetic Grease.

520 Attachment Set #003-520

Included with MicroBlock[®] Ball Vice #003-684.

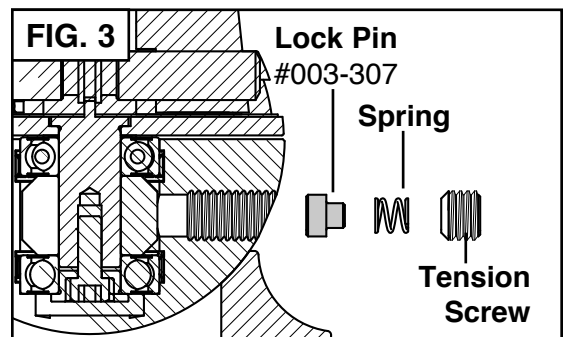

GRS[®] MicroBlock[®] Ball Vise

PARTS LIST • #003-683 & #003-684

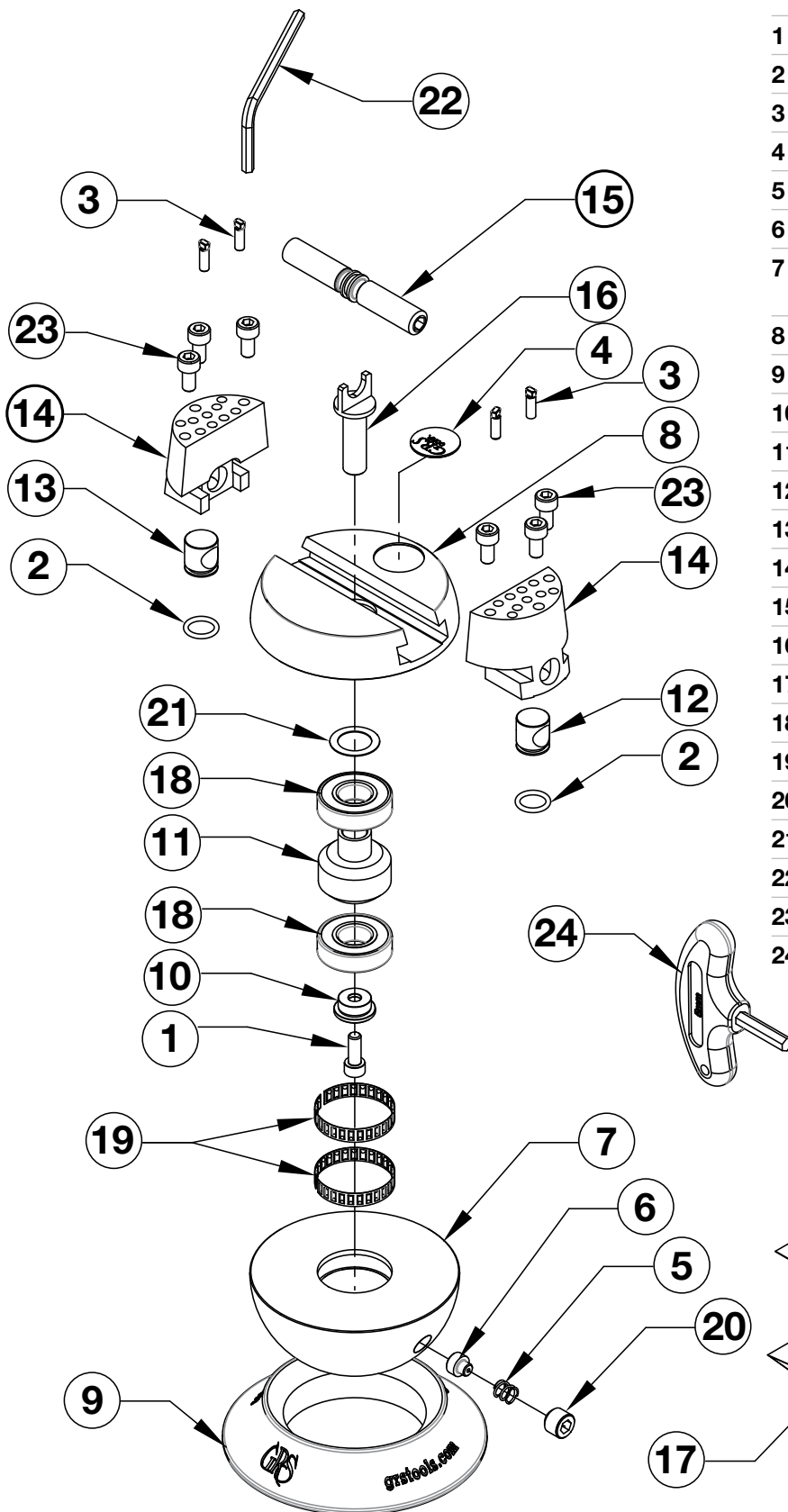

PART #	DESCRIPTION
1	002-067 SHCS, #10-32 X .50" BLK
2	002-084 O-RING, 3/8 X 1/2 X 1/16
3	003-050 FORMED COMPLETE ATTACHMENT PIN #1
4	003-140 LABEL, GRS
5	003-306 BRAKE AND DRAG SPRING
6	003-307 BRAKE ELEMENT FOR MICRO BLOCK VISE
7	003-308 416 STAINLESS STEEL 80MM BALL BASE FOR SMALL VISE
8	003-309 CROWN FOR MICRO BLOCK VISE
9	003-310-V2 BLACK MOLDED PLASTIC SUPPORT BASE
10	003-311 BEARING RETAINER FOR MICRO BLOCK VISE
11	003-496 BEARING SPACER BRAKE ROTOR MICROBLOCK
12	003-313 RIGHT HAND DIRVE NUT FOR MICROBLOCK
13	003-314 LEFT HAND DRIVE NUT FOR MICROBLOCK
14	003-315 MICRO BLOCK VISE JAW
15	003-317 JAW SCREW FOR MICRO BLOCK VISE
16	003-497 YOKE TO SUPPORT AND CENTER JAW SCREW
17	003-679 THERMO-LOC SAMPLE KIT
18	022-379 R8 SHIELDED BEARING
19	022-380 TOLERANCE RING
20	022-382 M10 X 1.5 FLAT NOSE SET SCREW X 8MM
21	022-383 .015 X .513 X .750 SS SHIM WASHER
22	022-822 4MM SHORT ARM HEX WRENCH
23	022-823 M5 X .8 X 10MM LONG SHCS
24	024-215 5mm X 25mm PLASTIC "T"HANDLE WRENCH

GLEND0 LLC

900 Overlander Road • Emporia, KS 66801 USA
 800-835-3519 • 620-343-1084 • Fax: 620-343-9640
 hello@grs.com • grs.com